

PLAN VIEW
DIMENSIONS
SCALE 1:30

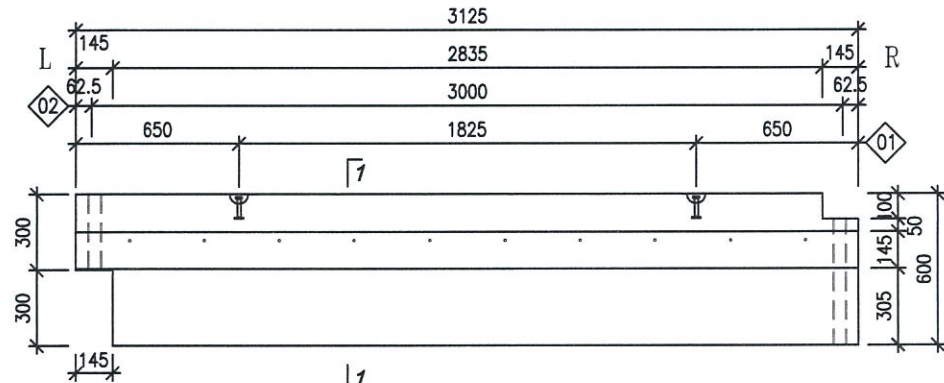

SIDE ELEVATION
DIMENSIONS
SCALE 1:30

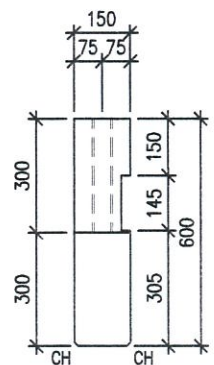

END OF BEAM (L)
DIMENSIONS
SCALE 1:20

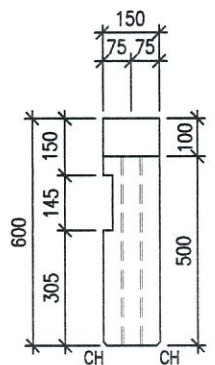

END OF BEAM (R)
DIMENSIONS
SCALE 1:20

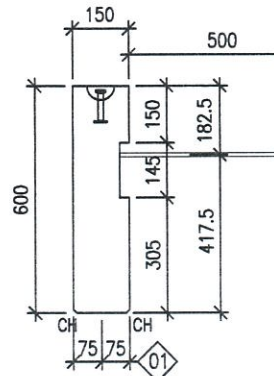

SECTION 1-1
DIMENSIONS
SCALE 1:20

CONCRETE	C35	BS 8110
REINFORCEMENT	T = GRADE 460 R = GRADE 250	BS 4449 BS 4449
WELDED FABRIC	GRADE 485	BS 4466
EXPOSURE	MODERATE	MS 145
CONCRETE COVER	25mm	GENERAL
SURFACES	GENERAL	OFF-FORM (STEEL) STEEL TROWELLED SMOOTH ROUGHEN SURFACE
CHAMFERS (CH)	10mm x 10mm	BS5606:1990
TOLERANCES	TABLE 2	CONCRETE CUBE STRENGTH FOR - FIRST LIFTING : >15 MPa - INSTALLATION : >25MPa LIFTING ONLY AT LIFTING POINTS
HANDLING		
NTS		NOT TO SCALE
N.F		NEAR FACE
F.F		FAR FACE
EF		EACH FACE

FOR MOULD

PELANGGAN

TAMBAHAN & COP KELUASAN PELANGGAN

NO. PERUBAHAN	REVISI	TARIKH	WJUD
0	1ST ISSUE-FOR MOULD	02/01/2020	LCY

TAJUK PROJEK
PROPOSED DEVELOPMENT ON 169.81 ACRES ON TITLE NO. C.L.045115919, KM 4, JALAN TUARAN - KOTA BELUD, SABAH. CONSISTS OF 833 UNITS OF DOUBLE STORY TERRACE AFFORDABLE HOMES & 800 UNITS OF 'PROJEK PERUMAHAN RAKYAT' AFFORDABLE APARTMENTS AND 17 UNITS OF DOUBLE STORY SHOPS

CONSULTANT

WK & PARTNERS
WE SHAPE INDUSTRIAL STRUCTURES

WK & Partners Consult Sdn Bhd (800089-V)
C-8-1, Putra Walk, Commercial Centre, Jalan PP25, Taman Pinggiran Putra
43000 Seri Kembangan, Selangor DE, Malaysia.
T +603 96495847 W www.wknp.com

TAJUK LUKISAN :	PRECAST BEAM B1
DISEKAN :	LCY
DIREKABENTUK :	TWE
DILUKIS :	FWF
SKALA :	AS SHOWN
TARIKH :	02/01/2020
NO. LUKISAN :	1901-E-B-B1
REV. :	0

FOR PRODUCTION

CONCRETE	C35	BS 8110
REINFORCEMENT	T = GRADE 460 R = GRADE 250	BS 4449 BS 4449
WELDED FABRIC	GRADE 485	BS 4466
EXPOSURE	MODERATE	MS 145
CONCRETE COVER	25mm	GENERAL
SURFACES	GENERAL	OFF-FORM (STEEL) STEEL TROWELLED SMOOTH ROUGHEN SURFACE
CHAMFERS (CH)	10mm x 10mm	BS5606:1990
TOLERANCES	TABLE 2	CONCRETE CUBE STRENGTH FOR - FIRST LIFTING : >15 MPa - INSTALLATION : >25MPa LIFTING ONLY AT LIFTING POINTS
HANDLING		
NTS		NOT TO SCALE
N.F		NEAR FACE
F.F		FAR FACE
EF		EACH FACE

HURUF PETUNJUK	PERAWAN	TARIKH	TIPOLOGI TAMBAH
0	1ST ISSUE	02/01/2020	LCY

TAJUK PROJEK
 PROPOSED DEVELOPMENT ON 169.81 ACRES ON TITLE NO. C.L.045115919, KM 4, JALAN TUARAN - KOTA BELUD, SABAH. CONSISTS OF 833 UNITS OF DOUBLE STORY TERRACE AFFORDABLE HOMES & 800 UNITS OF 'PROJEK PERUMAHAN RAKYAT' AFFORDABLE APARTMENTS AND 17 UNITS OF DOUBLE STORY SHOPS

CONSULTANT



WK & PARTNERS
 WE SHAPE INDUSTRIAL STRUCTURES

WK & Partners Consult Sdn Bhd (600909-V)
 C-8-1, Putra Walk Commercial Centre, Jalan PP25, Taman Pinggiran Putra
 43300 Seri Kembangan, Selangor DE, Malaysia.
 T +603 95495847 W www.wknp.com

TAJUK LUKOSAN :

PPR APARTMENT
 PRECAST BEAM
 B1

DISEKAN : LCY
 DIBENTUKAN : TMS
 DILUKIS : RNF

SKALA : AS SHOWN
 TARIKH : 02/01/2020

NO. LUKOSAN : 1901-E-B-B1
 REV: 0

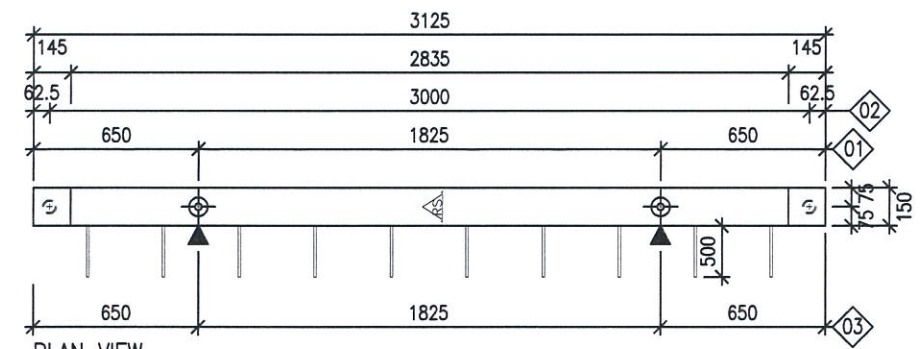

PLAN VIEW
 DIMENSIONS
 SCALE 1:30

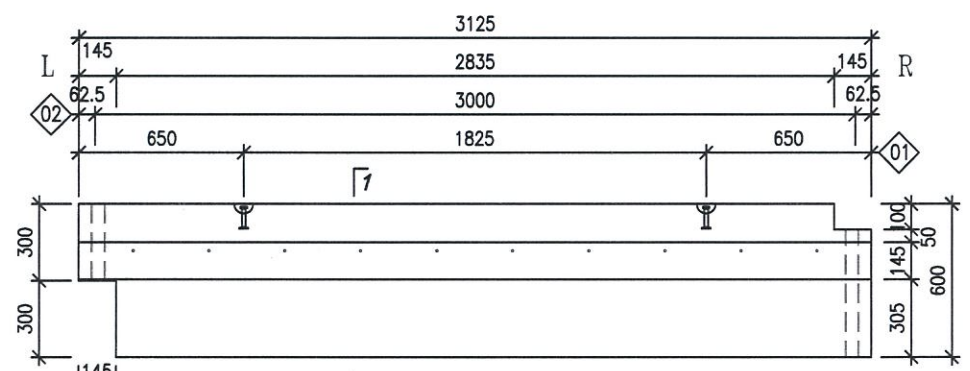

SIDE ELEVATION
 DIMENSIONS
 SCALE 1:30

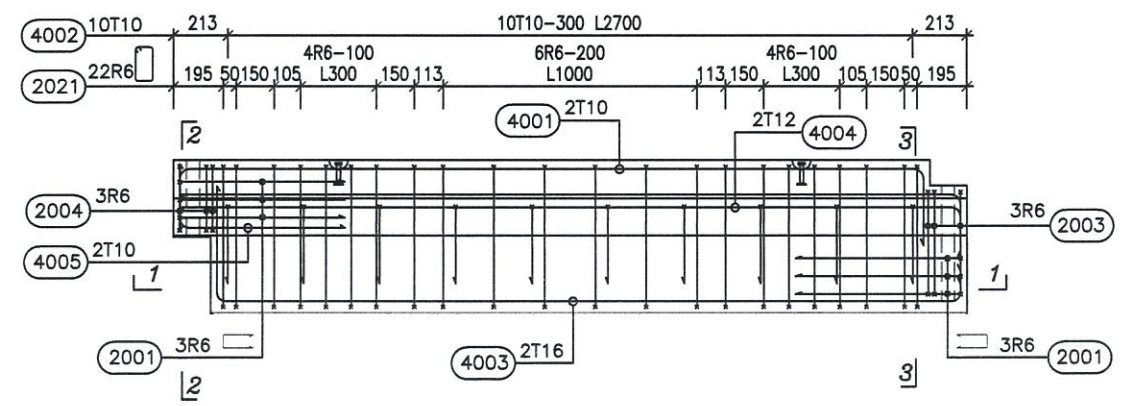

SIDE ELEVATION
 REINFORCEMENT
 SCALE 1:30

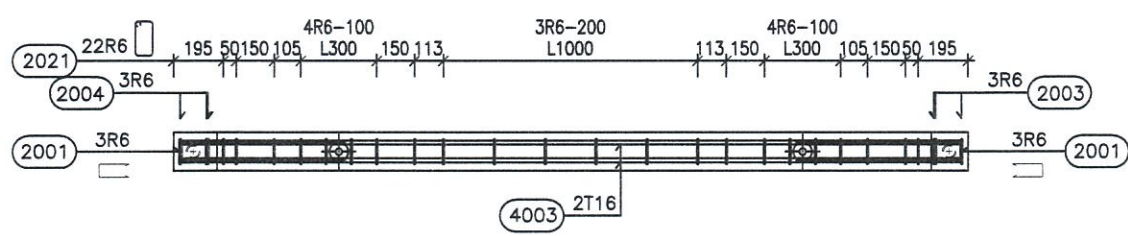

SECTION 1-1
 REINFORCEMENT
 SCALE 1:30

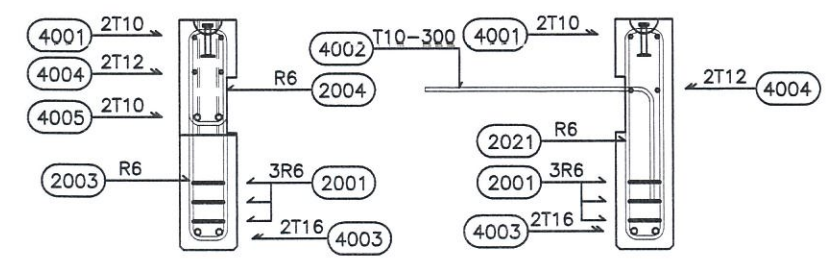
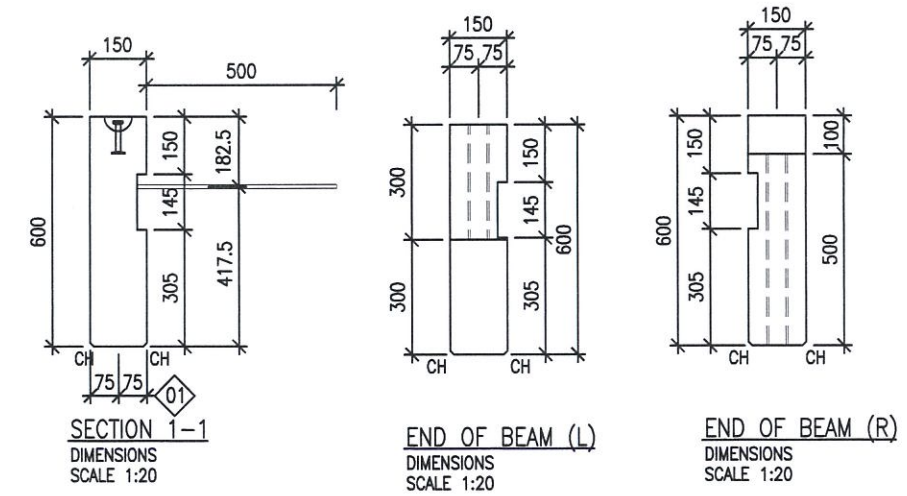

BAR BENDING SCHEDULE BS 4466										R=GRADE	T=GRADE	1901		E	B	MATERIALS				1901		E	B
Bar Mark	Type	Size	Nos	L	Shape Code	A	B	C	D	E/R	Former Dia.	Pos	Element	Material	Type	Size	Grade	Quantity	Remarks	Remarks	Remarks		
2001	R	6	6	1,376	38	650	100	650			24		Concrete		Volume		C35	0.70	t				
2002	R	8	3	1,296	61	500	100				32		Reinf. Bar	R		6-40		17	kg				
2004	R	8	3	796	61	250	100				32		Reinf. Bar	T		6-40		28	kg				
2021	R	8	22	1,496	61	600	100				32		Fabric				485		kg				
													Fabric					485		kg			
													Fabric					485		kg			
																		total		kg			
4001	T	10	2	3,420	38	240	2,930	300			60		Reinforcement					45	kg	184	kg/m3		
4002	T	10	10	875	37	600	300				60												
4003	T	16	2	3,600	38	450	2,930	300			96		01	Lifting Item	2.5ton Anchor			2	pcs				
4004	T	12	2	3,345	37	3,075	300				72		02	Corrugated Duct	CD 55-450	Ø55/45		1	pcs				
4005	T	10	2	875	37	250	650				60		03	Corrugated Duct	CD 55-155	Ø55/45		1	pcs				
													04	Hardwood		min b=50		2	pcs				

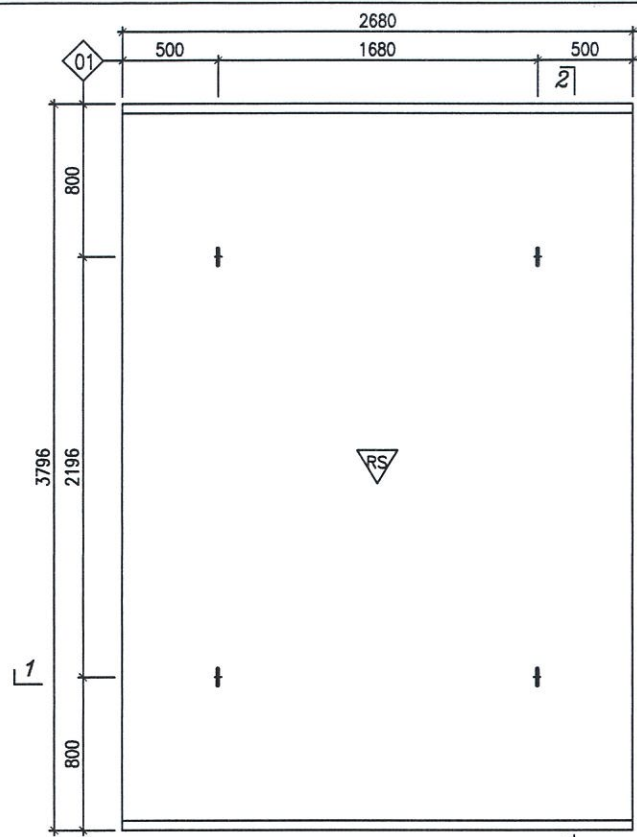

PLAN VIEW
DIMENSIONS
SCALE 1:40

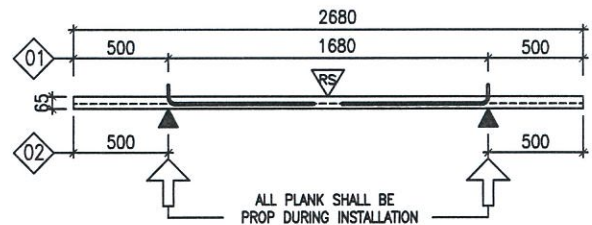

SECTION 1-1
DIMENSIONS
SCALE 1:40

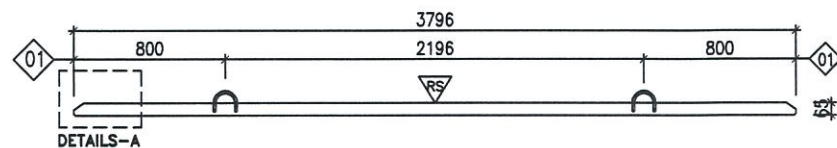

SECTION 2-2
DIMENSIONS
SCALE 1:40

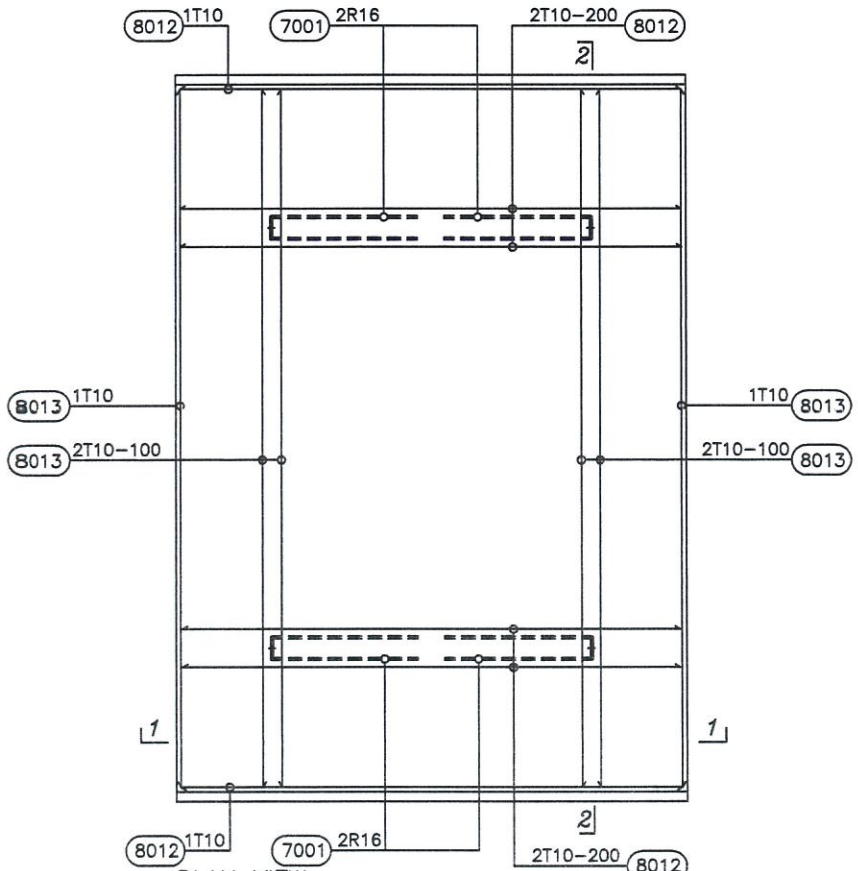

PLAN VIEW
TOP REINFORCEMENT
SCALE 1:40

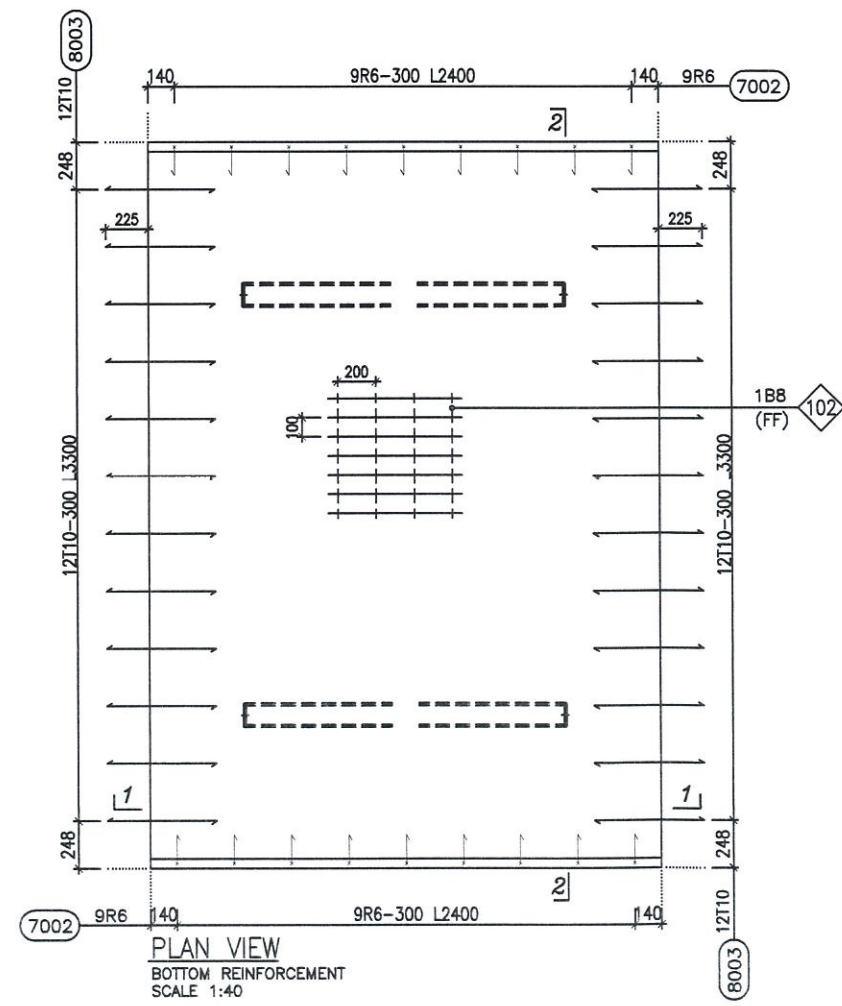

PLAN VIEW
BOTTOM REINFORCEMENT
SCALE 1:40

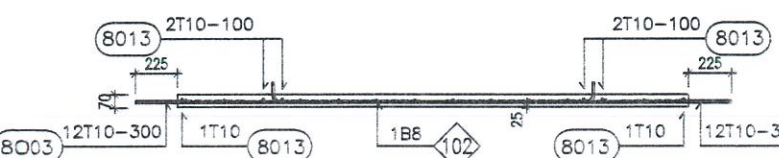

SECTION 1-1
REINFORCEMENT
SCALE 1:40

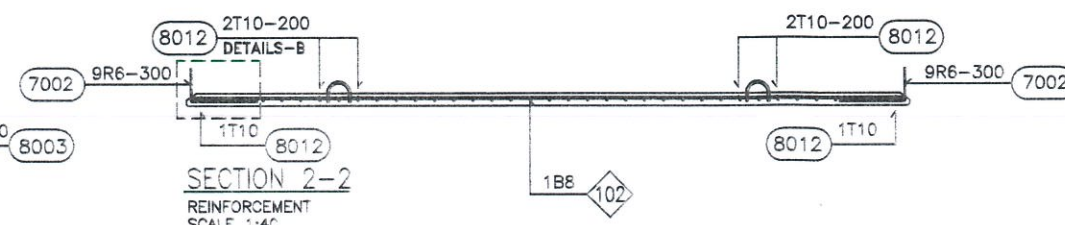

SECTION 2-2
REINFORCEMENT
SCALE 1:40

CONCRETE	C35	BS 8110
REINFORCEMENT	T = GRADE 460 R = GRADE 250	BS 4449 BS 4449
WELDED FABRIC	GRADE 485	BS 4466
EXPOSURE	MODERATE	MS 145
CONCRETE COVER	25mm	GENERAL
SURFACES	GENERAL	OFF-FORM (STEEL) STEEL TROWELLED SMOOTH ROUGHEN SURFACE
CHAMFERS (CH)	10mm x 10mm	BS5606:1990
TOLERANCES	TABLE 2	CONCRETE CUBE STRENGTH FOR - FIRST LIFTING : >15 MPa - INSTALLATION : >25MPa
HANDLING		LIFTING ONLY AT LIFTING POINTS
NTS		NOT TO SCALE
N.F		NEAR FACE
F.F		FAR FACE
EF		EACH FACE

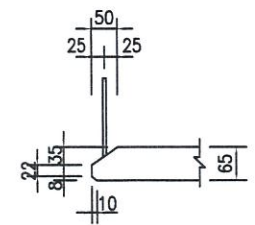
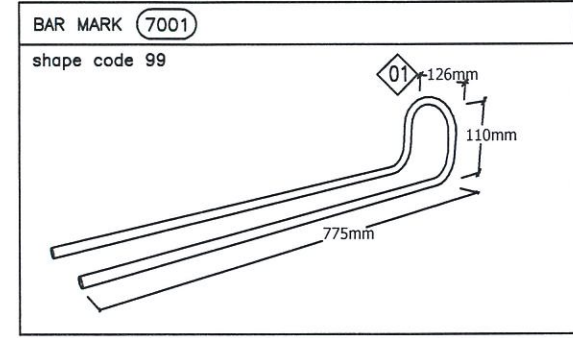

DETAIL-A
DIMENSIONS
SCALE 1:15

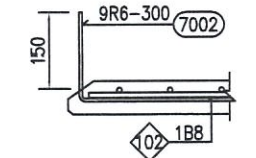

DETAIL-B
REINFORCEMENT
SCALE 1:15

BAR BENDING SCHEDULE BS 4466		R=GRADE	T=GRADE	1901		E	P
Bar Mark	Type	Size	Nos	L	Shape Code	Dimensions	Former Dia.
7001	R	16	4	1.896	99	775 110 126 110 775	96
7002	R	6	18	513	37	175 350	24
8003	T	10	24	550	37	175 400	60
8012	T	10	6	2.630	20	2.630	
8013	T	10	6	3.646	20	3.646	

MATERIALS		1901			E	P
Pos	Material	Type	Size	Grade	Quantity	Remarks
	Element	Weight			1.70	t
	Concrete	Volume		C35	0.66	m3
	Reinf. Bar	R	6 - 40		total 14	kg
	Reinf. Bar	T	6 - 40		total 31	kg
102	Fabnc	B8 - MS 145	2630 x 3746	485	58.4	kg 9.86x1pcx5.93kg/m2
					kg	
					kg	
					total 58	kg
	Reinforcement			Total	104	kg 157 kg/m3
01	Lifting Item		ØR16.L=1896		4	pcs
02	Hard Wood		min b=50		2	pcs

FOR PRODUCTION

HURUF	PERUBAHAN	TARIKH	ALASAN
0	1ST ISSUE	24/12/2019	LCY
1	REVISED PLANK SIZE	26/02/2021	LCY
	OMITTED	26/02/2021	

TAJUK PROJEK
PROPOSED DEVELOPMENT ON 169.81 ACRES ON TITLE NO. C.L.045115919, KM 4, JALAN TUARAN - KOTA BELUD, SABAH. CONSISTS OF 833 UNITS OF DOUBLE STORY TERRACE AFFORDABLE HOMES & 800 UNITS OF 'PROJEK PERUMAHAN RAKYAT' AFFORDABLE APARTMENTS AND 17 UNITS OF DOUBLE STORY SHOPS

CONSULTANT

WK & PARTNERS
 WE SHAPE INDUSTRIAL STRUCTURES
 WK & Partners Consult Sdn Bhd (660099-V)
 C-8-1, Putra Walk Commercial Centre, Jalan PP25, Taman Pinggiran Putra
 43300 Seri Kembangan, Selangor DE, Malaysia.
 T +603 95495847 W www.wkpc.com

TAJUK LUKISAN :
PPR APARTMENT
PPA-01

DISEKAN :	LCY
DIREKABENTUK :	TWS
DALAMAN :	FNF
SKALA :	1:40
TARIKH :	23/12/2019
NO. LUKISAN :	1901-E-P-PPA-01
REV :	1

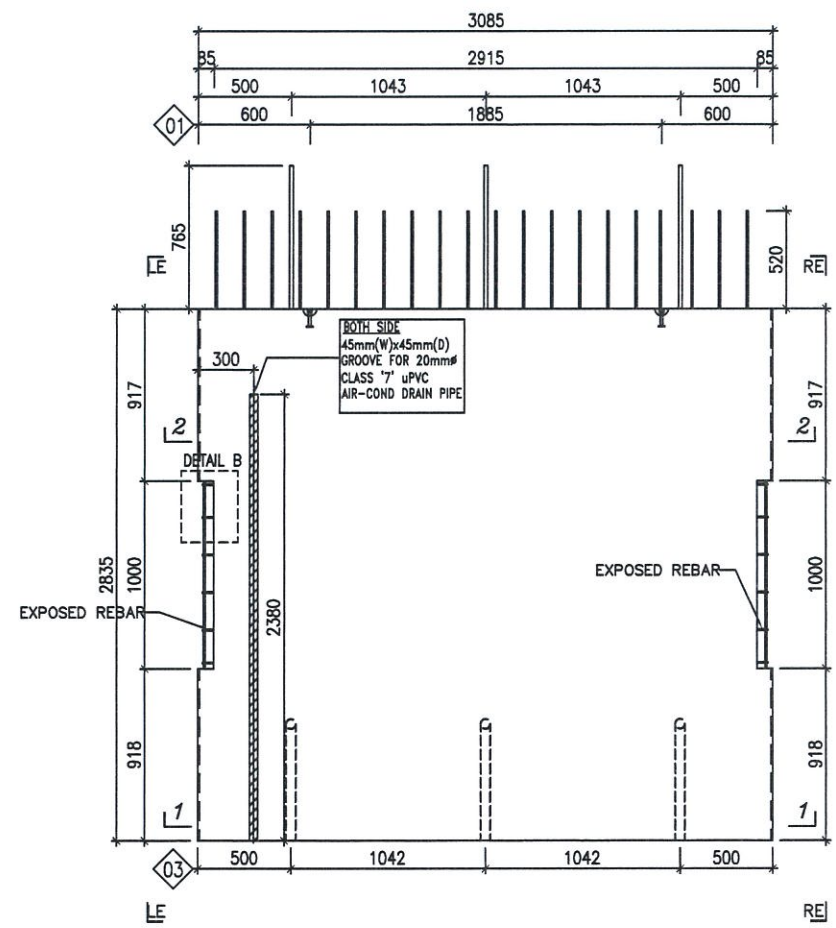

ELEVATION VIEW
DIMENSIONS
SCALE 1:40

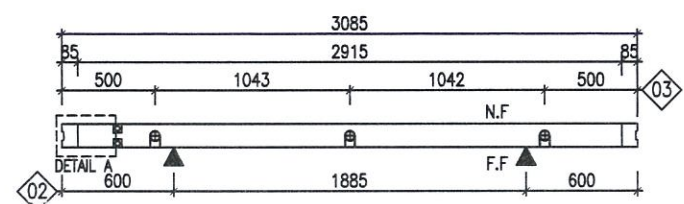

SECTION 1-1
DIMENSIONS
SCALE 1:40

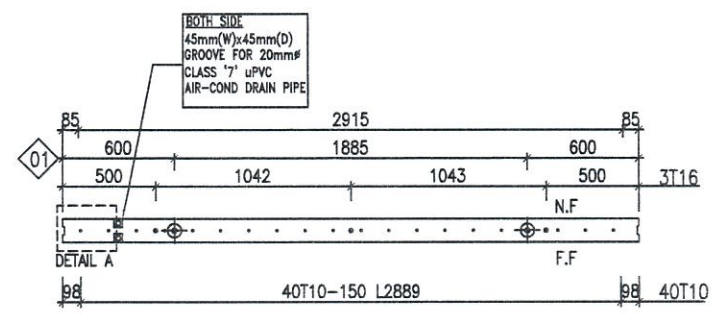

SECTION 2-2
DIMENSIONS
SCALE 1:40

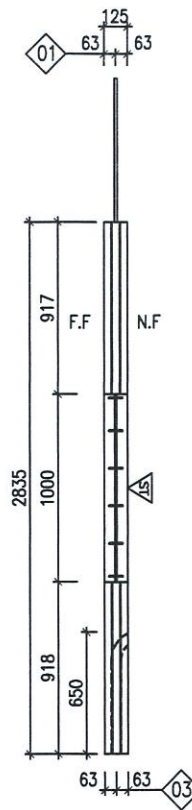

SIDE ELEVATION (LE)
DIMENSIONS
SCALE 1:40

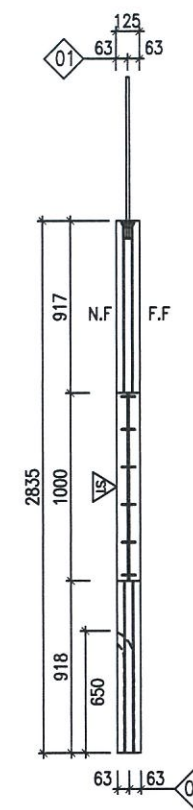

SIDE ELEVATION (RE)
DIMENSIONS
SCALE 1:40

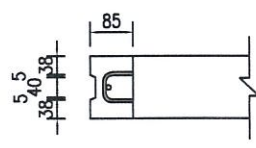

DETAIL A
DIMENSIONS
SCALE 1:15

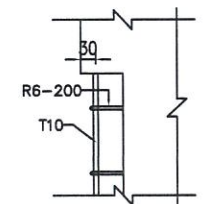

DETAIL B
DIMENSIONS
SCALE 1:15

FOR PRODUCTION

PELANGGAN
TAMBAHAN & CIP KELULUSAN PELANGGAN

HIRUF PERUBAHAN	PINDAAN	TARBIH	TINDA TANGAN
0	1ST ISSUE	20/12/2019	LCY
1	REVISED CONNECTION DETAILS	16/03/2020	LCY
2	REVISED AS PER CLOUD	08/08/2020	LCY
3	ADDED M&E	22/12/2020	LCY
4	REVISED M&E	02/03/2021	LCY

TAJUK PROJEK
PROPOSED DEVELOPMENT ON 169.81 ACRES ON TITLE NO. C.L.045115919, KM 4, JALAN TUARAN - KOTA BELUD, SABAH. CONSISTS OF 832 UNITS OF DOUBLE STORY TERRACE AFFORDABLE HOMES & 800 UNITS OF 'PROJEK PERUMAHAN RAKYAT' AFFORDABLE APARTMENTS AND 17 UNITS OF DOUBLE STORY SHOPS

CONSULTANT
WK & PARTNERS
WE SHAPE INDUSTRIAL STRUCTURES
WK & Partners Consult Sdn Bhd (860099-V)
C-8-1, Putra Walk Commercial Centre, Jalan PP25, Taman Pinggiran Putra
43300 Seri Kembangan, Selangor DE, Malaysia.
T: +603 95495847 W: www.wkppc.com

TAJUK LUKSAN :
**PPR APARTMENT
PANEL WV1
SHEET 1**

DISAMPAI : LCY
DIRUBAH/BERUBAH : TMS
DILAKUKAN : PWF
SIGAL : AS SHOWN
TARIKH : 20/12/2019
NO. LUKSAN : 1901-E-W-WV1 (A) REV: 4

NOTE:
1. CONTRACTOR SHALL PROPOSE METHOD OF STRENGTHENING TO THE PANELS DURING DEMOULDING AND LIFTING FOR ENGINEER'S APPROVAL PRIOR TO COMMENCEMENT OF WORK.
2. FORCIBLY DEMOULD IS STRICTLY NOT ALLOWED.

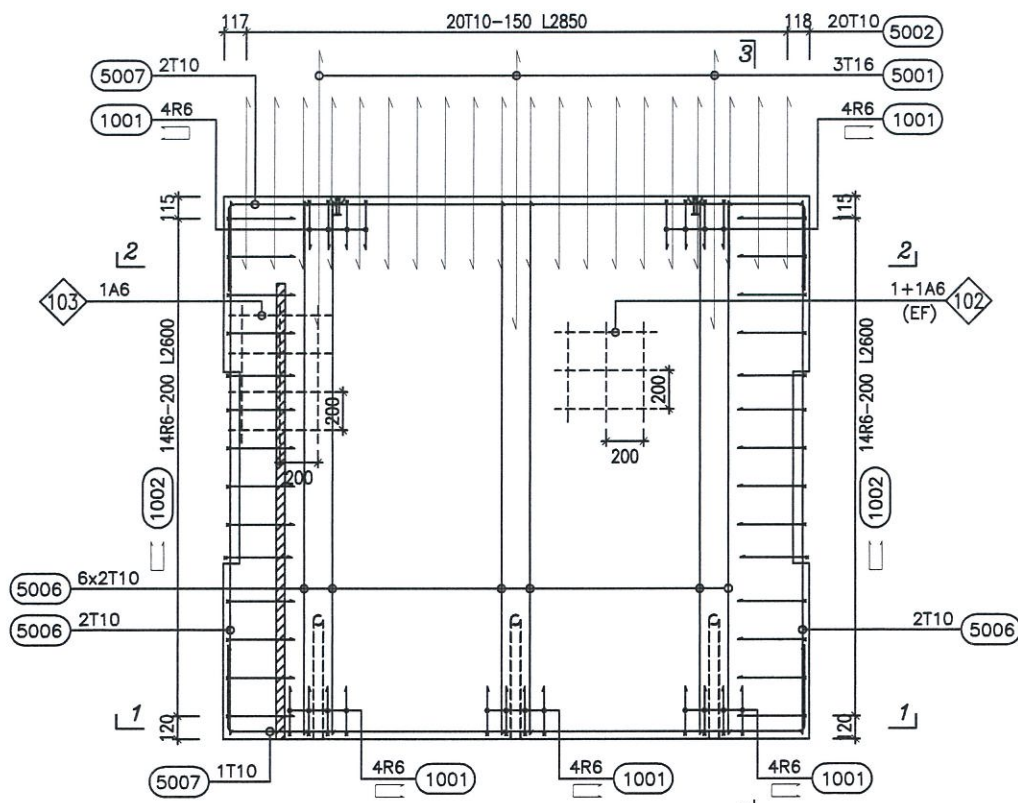

ELEVATION VIEW
REINFORCEMENT
SCALE 1:40

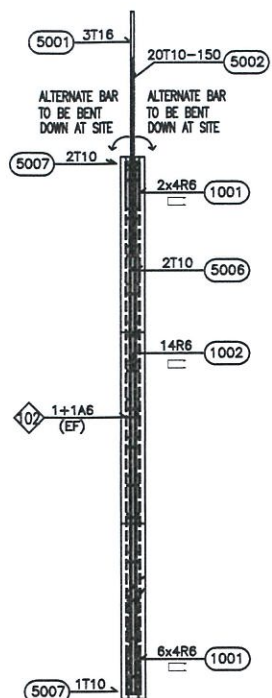

SECTION 3-3
REINFORCEMENT
SCALE 1:40

CONCRETE	C35	BS 8110
REINFORCEMENT	T = GRADE 460 R = GRADE 250	BS 4449 BS 4449
WELDED FABRIC	GRADE 485	BS 4466
EXPOSURE	MODERATE	MS 145
CONCRETE COVER	25mm	GENERAL
SURFACES	GENERAL	OFF-FORM (STEEL) STEEL TROWELLED SMOOTH ROUGHEN SURFACE
CHAMFERS (CH)	10mm x 10mm	BS5606:1990
TOLERANCES	TABLE 2	CONCRETE CUBE STRENGTH FOR - FIRST LIFTING : >15 MPa - INSTALLATION : >25MPa
HANDLING		LIFTING ONLY AT LIFTING POINTS
NTS		NOT TO SCALE
N.F		NEAR FACE
F.F		FAR FACE
EF		EACH FACE

FOR PRODUCTION

PELANGGAN			
TANDATANGAN & COP KELULUSAN PELANGGAN			
HURUF PETUALUK	PERUBAHAN	TARBIH	TANDA TANGAN
0	1ST ISSUE	20/12/2019	LCY
1	REVISED CONNECTION DETAILS	16/03/2020	LCY
2	REVISED AS PER CLOUD	08/09/2020	LCY
3	ADDED M&E	22/12/2020	LCY
4	REVISED M&E	02/03/2021	LCY

TAJUK PROJEK
PROPOSED DEVELOPMENT ON 169.81 ACRES ON TITLE NO. C.L.045115919, KM 4, JALAN TUARAN - KOTA BELUD, SABAH. CONSISTS OF 832 UNITS OF DOUBLE STORY TERRACE AFFORDABLE HOMES & 800 UNITS OF 'PROJEK PERUMAHAN RAKYAT' AFFORDABLE APARTMENTS AND 17 UNITS OF DOUBLE STORY SHOPS

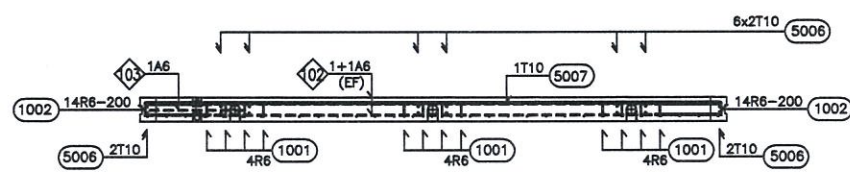

SECTION 1-1
REINFORCEMENT
SCALE 1:40

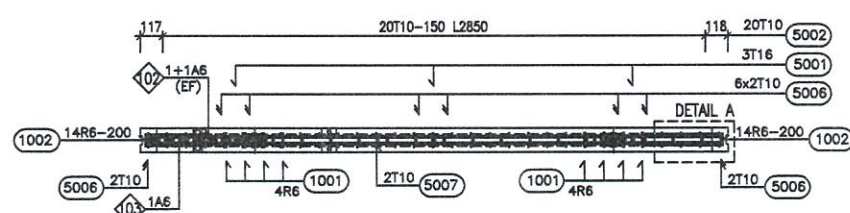

SECTION 2-2
REINFORCEMENT
SCALE 1:40

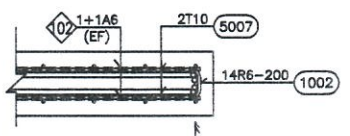

DETAIL A
REINFORCEMENT
SCALE 1:15

BAR BENDING SCHEDULE					R = GRADE		T = GRADE		1901		E		W			
Bar Mark	Type	Size	Nos	L	Shape Code	A	B	C	D	E/R	Former Dia.	WV1				
1001	R	6	20	551	38	250	75	250			24					
1002	R	6	28	736	38	350	60	350			24					
5001	T	16	3	1,460	20	1,460										
5002	T	10	20	900	20	900										
5006	T	10	16	2,785	20	2,785										
5007	T	10	3	3,885	38	450	3,035	450			60					
MATERIALS											1901		E		W	
Pos	Material	Type	Size	Grade	Quantity	Remarks		WV1								
	Concrete	Volume		C35	1.07	m3										
	Reinf. Bar		6 - 40		7	kg										
	Reinf. Bar		6 - 40		53	kg										
102	Fabric	A6 - MS 145	3035 x 2785	485	37.5	kg		8.46x2pcx2.22kg/m2								
103	Fabric	A6 - MS 145	500 x 2785	485	3.1	kg		1.4x1pcx2.22kg/m2								
						kg										
					41	kg										
	Reinforcement			Total	100	kg		94 kg/m3								
01	Lifting item	2.5tons Anchor			2	pcs										
02	Hard Wood	min b=50			2	pcs										
03	Comugated Duct	Ø50/55 L=650			6	pcs										

CONSULTANT
WK & PARTNERS
WE SHAPE INDUSTRIAL STRUCTURES
WK & Partners Consult Sdn Bhd (860099-V)
C-8-1, Putra Walk Commercial Centre, Jalan PP26, Taman Pinnangren Putra
43300 Seri Kembangan, Selangor DE, Malaysia.
T +603 95495847 W www.wkpc.com

TAJUK LUKISAN :
PPR APARTMENT
PANEL WV1
SHEET 2

DISEKAN : LCY
DIREKABENTUK : TWS
DILUKIS : RNF
SKALA : AS SHOWN
TARBIH : 17/12/2019
NO. LUKISAN : 1901-E-W-WV1 (B)
REV : 4